



Entrance Permit Application and Process

10836 County Road 2, P.O. Box 70, Grafton, ON K0K 2G0
Phone (905) 349-2822 Fax (905) 349-3902

Guidelines

- The Owner of the property (Applicant) shall take out a permit for any entrance installation, adjustment, improvement or removal. Fees & deposits must be paid in full and a site plan showing the location of the entrance shall be attached to the permit application.
- The Applicant shall mark the site at the proposed location of the entrance with stakes/paint.
- Road Operations staff will determine the diameter, the length and the type of culvert required. This information will be recorded on the Permit. Only new culverts will be approved.
- Road Operations staff will determine the need for additional work required (i.e. ditching, grading, catch basin, sidewalk replacement, curb replacement, etc.).
- Road Operations staff will approve the location of the proposed entrance, based on existing conditions; sightlines etc. or recommend an alternative location. New entrances **will not** be permitted at the following locations:
 - Where access can reasonably be gained from a right-of-way
 - Within an exclusive lane for channelization, acceleration or deceleration
 - Within 30 metres of an intersection where the posted speed is 80 km/hr or more
 - Within 30 metres of bridge termination where the posted speed is 80 km/hr or more
 - Within 30 metres of an at grade railway crossing
 - Where crossing through existing guide posts, guide rails or steel beam
 - Where minimum stopping sight distances are not met
 - Where in the opinion of the Public Works Superintendent or designate, an entrance will result in a negative or unsafe situation for the travelling public.
- A copy of the approved permit will be provided to the Applicant (within 10 business days) and **no work shall commence prior to** receiving the approved permit.
- If a Contractor is doing the work, the permit must also be signed by the Contractor acknowledging the specifications as required by Road Operations staff.
- When the entrance is complete, the Applicant is required to submit the Application for Refund of Deposit to initiate final inspection of the entrance. ***Note*: If this application is tied to a Building Permit, you must attach a copy of your completed Occupancy Inspection from the Chief Building Official to the completed refund application.**
- If the entrance does not pass inspection, the Owner will have ten (10) business days from notification date, to make corrections.
- If corrections are not completed within ten (10) business days, Road Operations staff shall arrange for the necessary work to be completed, deducting actual costs from the deposit, and invoicing the Owner for any additional costs.

Special Notes:

- If an entrance location is not approved, or if the Applicant/Contractor is not proceeding with the entrance, the deposit will be returned upon completion and submission of the entrance refund application form to your local municipality. Please note, the administrative fee is non-refundable.
- All costs such as labour, materials, and machinery to perform the work are borne by and the responsibility of the property owner and/ or the person named in the permit.
- The Owner is required to maintain the existing drainage patterns during installation of the entrance, to be approved subject to final inspection by Road Operations staff.
- If the property is within Conservation Regulated Lands, the applicant will be notified by the municipality and directed to the appropriate Conservation Authority. A copy of the approved Conservation Permit will be required prior to the issuance of the approved Entrance Permit.
- The Applicant is responsible to arrange for all utility locates in the area of the works.
- Side slope shall be no less than 2:1 measured from the driving surface to the end of pipe.
- Paving of the area from the edge of pavement to the property line, must be approved by Road Operations staff and the cost borne by the property owner.
- Expiry date of the permit is generally one (1) calendar year from the date on the permit. The Applicant may apply for an extension of the permit, and carry over the deposit; providing Road Operations is notified in writing prior to the expiration date on the permit. Should the permit expire prior to work being started, the security deposit shall be returned to the permit holder, and a new application will be required for the work. The administrative fee is non-refundable.
- Each entrance must be designed, constructed and maintained in a manner that prevents surface water from the entranceway and/or the adjoining property from being discharged via the entrance onto the roadway.
- The applicant/contractor must ensure that all other applicable permits (road occupancy, permission to enter etc.) and underground locates are obtained prior to any work taking place.

Types of Entrances

Agricultural Entrance: Is an entrance used to access agricultural fields and vacant lands.

Commercial Entrance: Is an entrance used to access a business where goods or services are sold, or to access residential facilities of five (5) or more units.

Residential Entrance: Is an entrance used to access residential facilities of four (4) units or less.

Temporary Entrance: Is an entrance used to access properties for a limited period, not to exceed one (1) year, for the purpose of construction, repairs or improvements on the property or to facilitate a staged development.



ENTRANCE PERMIT APPLICATION

10836 County Road 2 P.O. Box 70
Grafton, ON K0K 2G0
Phone (905)349-2822 Fax (905) 349-3902

Please Print

FOR OFFICE USE	
Permit # _____	
Received By _____	
Date _____	
Amount Pd. _____	

Registered Owner(s): _____

Mailing Address: _____

Telephone Numbers: Home: _____ Cell: _____ Fax: _____

Email Address: _____

Copy of approved Entrance Permit to be received by: Email Fax Pick-Up Mail

I hereby make application to Construct/New Alter / Improve Remove
 Residential Commercial *Agricultural entrance at:

Lot _____ Concession _____ in the Town/Township of _____

On the _____ side of _____ (Road/Street etc.)

Property Roll # _____ Civic# (if applicable) _____

Is a Building Permit required? Yes No Is a Conservation Permit Required? Yes No

Could the entrance be made via another road? Yes No

I understand that this is only an application and the entrance is not to be installed until the permit has been paid for and issued by the Public Works Department. Entrance deposit refund must be applied for between the months of **April - November** and within 2 years of the date of application. Failure to do so will result in forfeiture of the deposit.

Date of Application: _____ Signature: _____

Name of Contractor: _____ Signature: _____

The following items must be submitted with this application:

1. A copy of a legal survey and/or site plan.
2. A copy of the deed - only required if property has recently been purchased or transferred.
3. A sketch showing the location of the proposed entrance and other landmarks. Please provide measurements.
4. Payment (\$250.00 Application Fee + \$1,250 Refundable Deposit, if applicable) **\$1,500.00** paid by cheque, debit or cash.

*To obtain an Emergency Access number for an Agricultural entrance, please contact Dianne Nicholls at 905-352-1142 to complete a separate application form.

FOR OFFICE USE ONLY

To be completed by inspector:

Recommendations: _____

Prepared By _____ Date _____

Ontario Provincial Standard Drawing attached: OPSD - 301.010 MOD.____ OPSD - 301.020 MOD.____
OPSD - 350.010 MOD.____ OPSD - 351.010 MOD.____

Preliminary Site Inspection:

Culvert Required? Yes___ No ___ Culvert Size (Diam.) _____ mm , Length _____ m

Comments: _____

Inspected By: _____ Date Inspected: _____

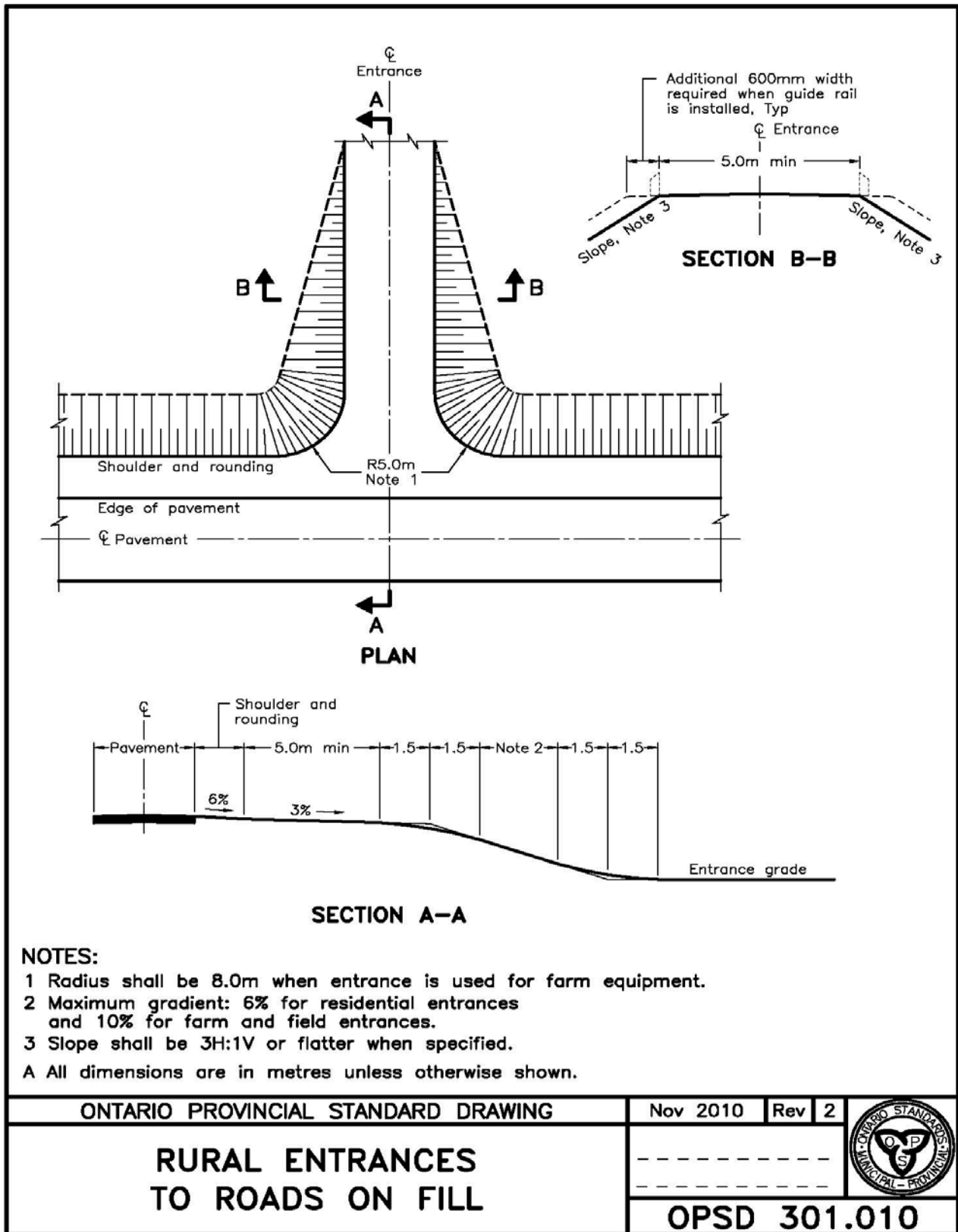

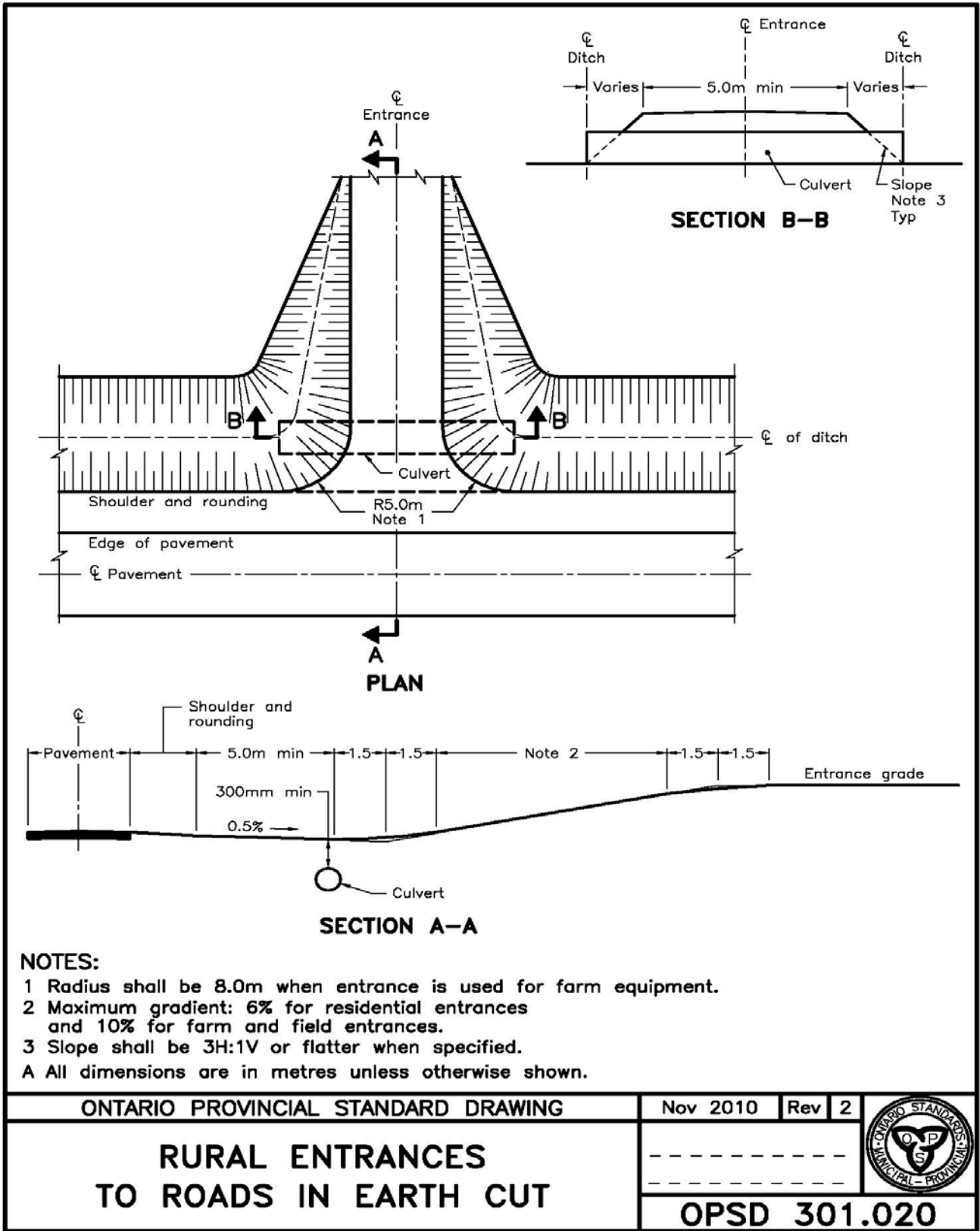

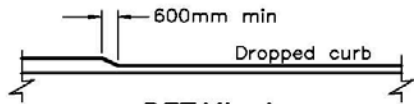
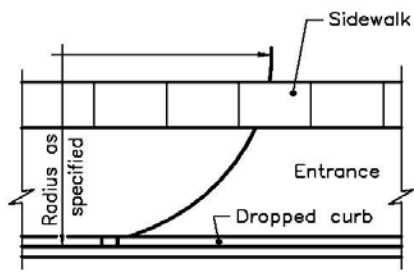

DETAIL A

DRIVEWAY DIMENSIONS						
LAND USE	WIDTH m				RADIUS m	
	One-Way		Two-Way		min	max
	min	max	min	max		
Light Industrial, Commercial, and Apartment	4.5	7.5	7.2	12.0	4.5	12.0
Heavy Industrial	5.0	9.0	9.0	15.0	9.0	15.0

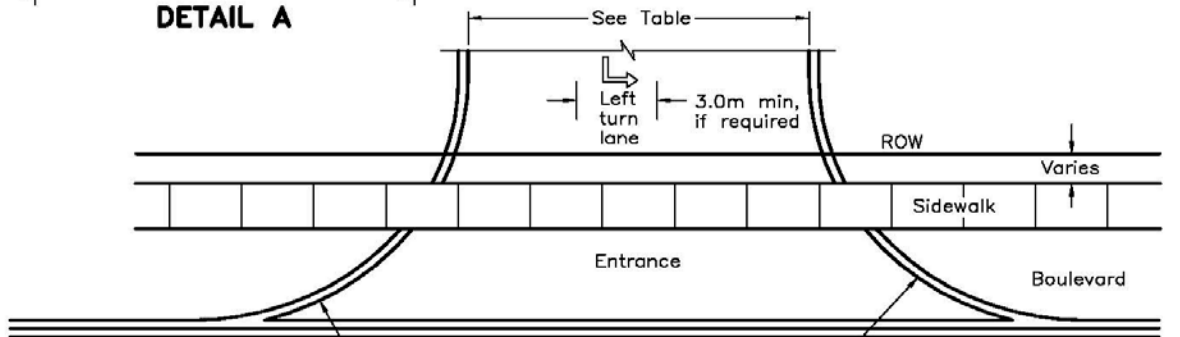

PLAN

Concrete curb or curb with gutter. For entrance without curb or curb with gutter see Detail A

See table for driveway radius

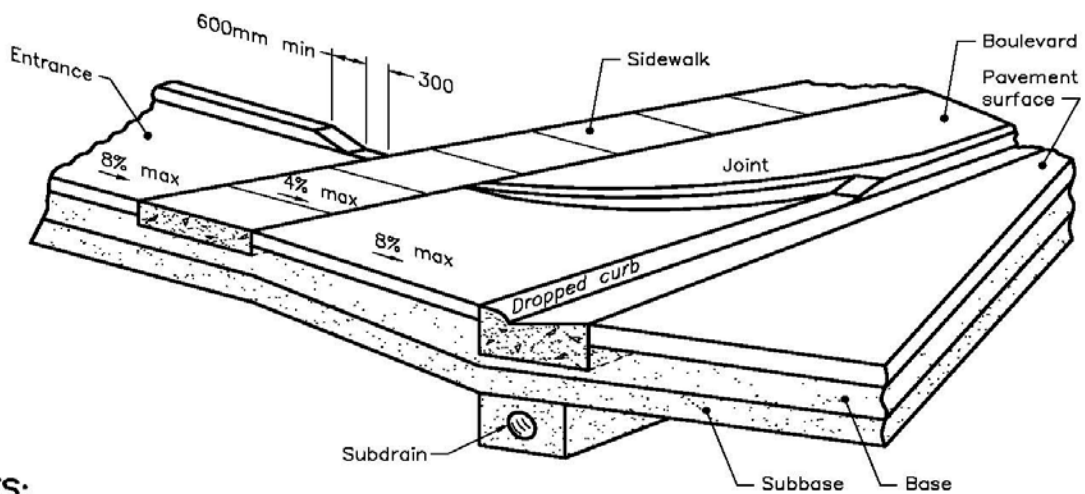

NOTES:

A All dimensions are in millimetres unless otherwise shown.

ONTARIO PROVINCIAL STANDARD DRAWING URBAN INDUSTRIAL, COMMERCIAL, AND APARTMENT ENTRANCES	Nov 2009 Rev 1 ----- ----- OPSD 350.010	
--	---	---

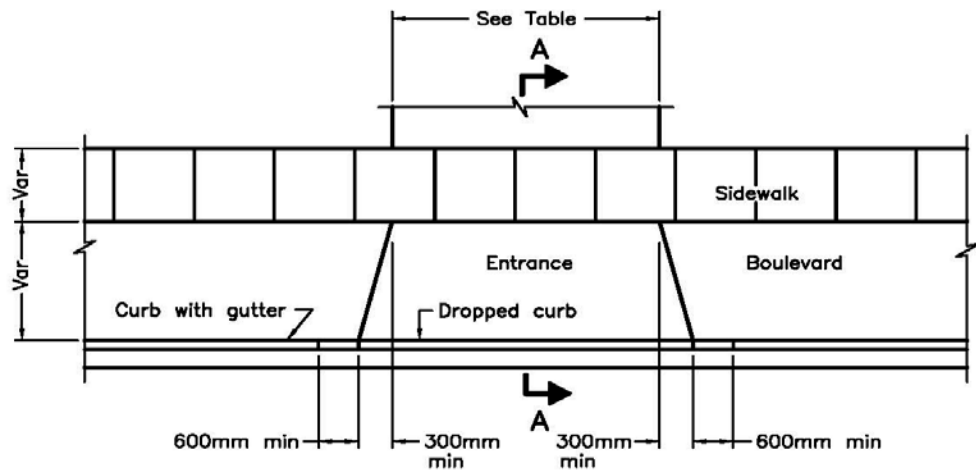

PLAN

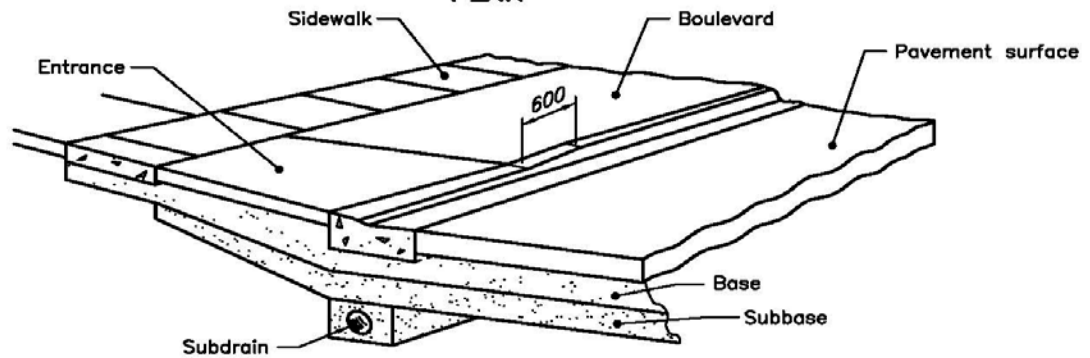

ISOMETRIC VIEW

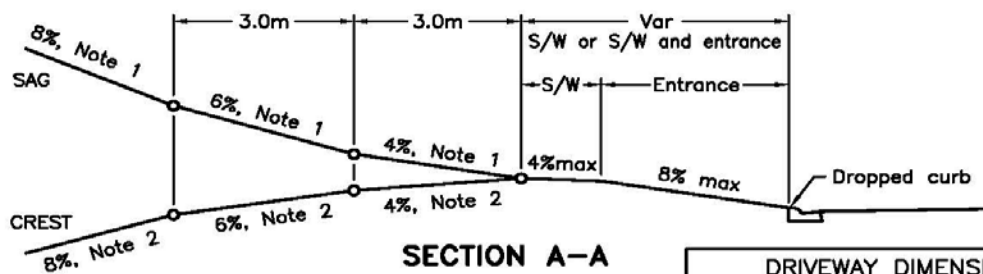

SECTION A-A

NOTES:

- 1 Maximum upgrade shall be 10%.
- 2 Maximum downgrade shall be 8%.

A All dimensions are in millimetres unless otherwise shown.

DRIVEWAY DIMENSIONS				
LAND USE	WIDTH m			
	Single		Double	
	min	max	min	max
Residential	3.0	4.3	6.0	7.3

ONTARIO PROVINCIAL STANDARD DRAWING

Nov 2009 Rev 1

**URBAN RESIDENTIAL
ENTRANCE**

OPSD 351.010

